

Guarding the Health and Availability of a Brushless Generator Using an Earth Fault Resistance Monitor

By

John Demcko, Senior Consulting Engineer, Arizona Public Service Company
John Reschovsky, President, Accumetrics Associates, Inc.

Introduction

Arizona Public Service Company (APS) views field grounds on its synchronous generators as serious events. To that end APS has embarked on a program to review and upgrade field ground detection capabilities across its entire generation mix. This has been a relatively easy task on machines with collector rings and brushes. The process has been more demanding on brushless generators. This paper describes the process and results of an upgrade to field ground detection capabilities to the brushless exciter equipped combustion turbine generator of the West Phoenix #4 combined cycle unit. The unit was commissioned the spring of 2002 and was equipped with a field ground detection unit selected by the turbine generator manufacturer.

During the review process, it was discovered that the ground fault detection system had been inoperative since the turbine generator was commissioned. The wires connecting the transmitting unit to the generator field were found unterminated. The OEM supplied device was only capable of providing a ground/no ground indication. Given the field ground issues that APS had recently experienced on other units, it was decided to upgrade West Phoenix unit 4 to a state of the art device with greater capabilities than just go/no go detection. Based on a review of available technology, an Earth Fault Resistance Monitor (EFREM) manufactured by Accumetrics Associates, Inc. was purchased for installation on West Phoenix CC4 combustion turbine generator in the spring of 2006.

The Earth Fault Resistance Monitor (EFREM)

The EFREM is a system that provides continuous monitoring of insulation fault resistance on generator field windings and associated excitation circuitry. To do this, it uses advanced ground fault measurement techniques, working in concert with the latest innovations in digital telemetry. Unlike other field ground detection devices that only periodically check for faults and provide only go/no go alarm outputs, the EFREM continuously provides quantitative information about fault severity and records data trends.

There are relatively few components to the EFREM system: the transmitter, the pickup coil, the receiver, and a couple of cables. The transmitter is mounted on the end of the shaft. If access to the end of the shaft is unavailable, the transmitter can also be mounted around the exciter shaft. A stationary pickup coil mounted in close proximity to the transmitter transfers a radio frequency power signal to energize the rotating transmitter electronics and to receive digital signals from the transmitter. A cable connects the pickup to the EFREM receiver, and an Ethernet cable connects the receiver to a PC, where the data can be viewed.

Presented at ELECTRIC POWER 2007 Conference, May 1-3, 2007, Chicago, IL (USA).

The EFREM transmitter makes three connections to the machine:

- To the rotor ground
- To the plus field bus terminal
- To the minus field bus terminal

When a fault occurs—shown on **Figure 1** below as a resistor (R_L)—a current flows through the fault detection circuitry. The magnitude of this current depends on the value of R_L , but it also depends upon the location of the fault along the field winding. This location is characterized by a Location Factor, K . K takes a value of 0% at the negative field terminal, increasing for faults along the winding to 100% at the positive field terminal. To measure the fault resistance independently of Location Factor, the EFREM's transmitter circuitry injects a pulsed voltage between the field negative bus and the rotor ground. The current flowing from the ground terminal into the transmitter is digitized with high resolution and transmitted off the rotor using wireless techniques. A computation of the change in current as the pulse transitions allows the resistance, R_L , as well as the location factor, K , to be independently computed. The total excitation voltage, V_X is also digitized and transmitted off the rotor, providing supplemental information about the operation of the exciter. All this information is continuously stored and may be archived, allowing operators to study historic trends.

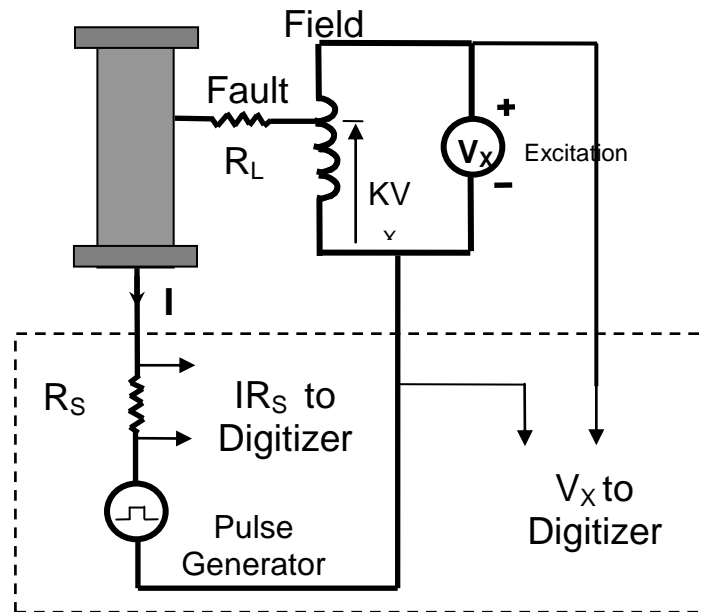

Figure 1
Earth Fault Detection Methodology for Accumetrics'
Earth Fault Resistance Monitor

The EFREM provides continuous monitoring for ground faults, even when the generator is off-line. Unlike any other ground fault monitoring system, the EFREM is unique in providing machine operators with the following:

- Quantitative resistance measurement of fault severity
- Continuous trending and charting of fault resistances
- Fault location indication for easy diagnosis and repair
- Field excitation voltage monitoring which may be useful in diagnosing shorted turns
- Alarm relay outputs for multiple resistance levels that can be used to activate warnings or shut down machines

The bottom line is that with the EFREM installed, the machine operator can immediately know: if there is a fault, how severe it is, what the trend is (Is it getting worse? If so, how fast?), and where the fault is. Further, the timeline provided by the EFREM gives a clear indication of how quickly action must be taken. Armed with the EFREM, operators can protect the rotor from catastrophic failure and help predict when maintenance will be needed so that outages can be planned.

Installation Experience

Installation consists of mounting both stationary and rotating EFREM components, making connections to the generator field and interfacing EFREM outputs to external device(s). **Figure 2** is a photo of the unit's brushless exciter supplied to the generator manufacturer by a domestic company.



Figure 2
Brushless Exciter Overview

The alternator and diode wheel are contained within the housing with the diode wheel mounted closest to the end of the shaft. A circular steel end plate protects plant staff from direct contact with the rotating diode wheel. The standard EFREM transmitter package resembles a top hat or

a disk with a small snout extending from its outer face. The transmitter is mounted to the shaft end by a three bolt hole pattern determined by the manufacturer. The shaft end had a four bolt hole pattern already drilled and tapped. **Figure 3** documents the shaft bolt hole pattern and diode wheel with the circular steel end plate removed. Since the existing shaft bolt hole pattern did not match the EFREM transmitter pattern, an adaptor plate was fabricated.



Figure 3
Shaft End Hole Pattern & Surrounding Diode Wheel

Figure 4 is a photo of the adaptor plate (top left), EFREM transmitter “top hat” (top right) and stationary pickup. The EFREM transmitter was then easily fitted to the shaft end. A bracket to hold the stationary receiver pickup over the transmitter was also fabricated and mounted across the diode wheel inspection hatch.



Figure 4
**Adapter Plate, EFREM Transmitter “Top Hat”
& Stationary Pickup**

Figure 5 documents the installed transmitter and stationary receiver pickup. Note that the existing diode wheel inspection hatch could not be reinstalled without modification. The reasons for this are twofold. First, the shaft length has been increased by the EFREM transmitter and adaptor plate. This lengthening, along with shaft expansion might cause a rub with the inspection hatch. Second, if the steel inspection hatch is mounted too closely to the stationary pickup, it might cause the system to detune.



Figure 5
Mounted Adaptor Plate, Transmitter & Receiver Pickup Loop

A simple extension to the cover plate was fabricated to allow approximately six inches of clearance between the induction loop and the ferrous cover plate. **Figure 6** is a photo of the completed cover plate extension.



Figure 6
Diode Wheel Inspection Hatch Extension For Additional Clearance

Last, **Figure 7** documents the installation of the EFREM Receiver and Power Supply unit. It was mounted on the wall of the exciter housing within a few feet of the EFREM transmitter. The cabling run to connect the receiver to the pickup coil was made through flexible conduit and is approximately 25 feet long. External connections to the receiver include ac power, pickup coil, alarm contacts and local network to a logging computer in the plant control room. Upon unit startup, no rebalancing of the unit was required after installation, and there was no measurable increase in diode wheel end bearing vibration. The skill set required to fabricate parts and mount the EFREM was well within the capabilities of the plant's electrical and mechanical personnel, and the time required to do the installation was not excessive.



Figure 7
EFREM Receiver Mounted on Exciter Cubicle Wall

Operational Experience

West Phoenix Combined Cycle Unit 4 is typically run as a peaking unit due to fuel costs. The EFREM installation was completed in the first quarter of 2006. EFREM showed that the measured field resistance to ground was 20M Ω on turning gear. We anxiously awaited run season to assess EFREM's performance on-line. The EXCEL plot below (**Figure 8**) documents the measured field resistance measured to ground at 1 minute intervals for July 20th through July

27th, 2006. Generator field voltage, denoted as V_{fd} , is also plotted as an indicator of when the machine was in service since the unit was cycled in this time frame.

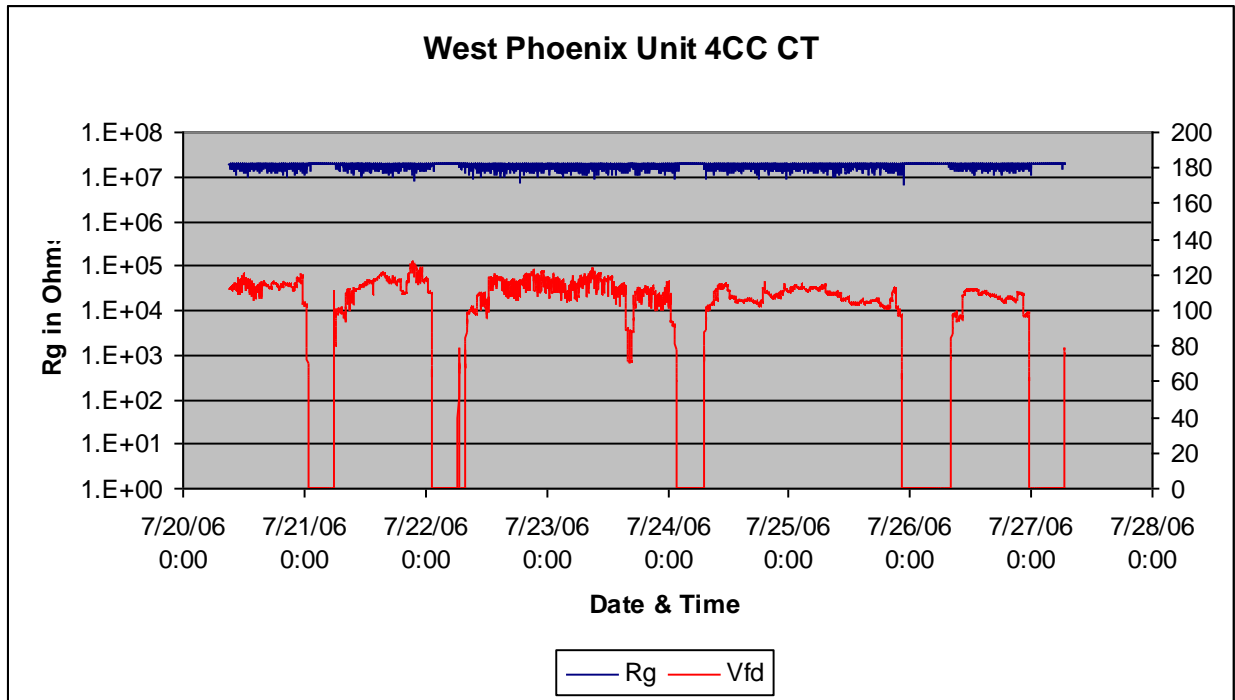

Figure 8
Typical EFREM Data

The plot shows that measured field resistance to ground during this time frame remained on the order of 15 to 20MΩ. Note that when the unit was offline ($V_{fd} = 0$) field resistance to ground was indicated as 20MΩ, the maximum measurable value for EFREM at that time. When the machine was online as indicated by a non-zero reading of V_{fd} , field ground resistance values were between 15 and 20MΩ. These values indicate that the generator field winding insulation system, the diode wheel insulation system and the alternator 3 phase winding insulation system are all in excellent condition. Data consistent with these field to ground resistance levels were recorded through August and into September. This baseline data was to become very useful in evaluating an event in early September.

Late on the evening of September 2, 2006, the plant operators informed engineering of a U4CC CT field ground alarm indication on the plant's distributed control system (DCS) computer displays. The alarm would not clear. An extremely violent thunderstorm had hit the metropolitan Phoenix area that evening with severe flooding in the vicinity of the West Phoenix plant. The operators also reported that the data logging computer had locked up sometime during the storm. This does not disable EFREM's capability to detect and alarm ground faults—it only precludes logging of field resistance to the machine's hard drive.

Upon arrival at the plant site, the EFREM data logging software was restarted to confirm what the alarm had already told us. The field resistance to ground was below 100,000Ω. With the unit offline and on turning gear, EFREM logging software showed the calculated field resistance to be just 10,700Ω! The flooding around the plant was severe with catch basins overflowing. Given the heavy rain, it was theorized that the air cooled generator and brushless exciter may have ingested water through its circuitous cooling paths when it was operating during the height of the rain storm.

Since the machine was still relatively warm and it would be need to meet the next day’s peak, a decision was made to run the machine up to synchronous speed, turn on the excitation system and closely monitor field resistance to ground. The EXCEL plot below (**Figure 9**) documents a rapid rise in measured resistance from 10,700Ω to values in the 15 to 20MΩ range to ground that coincides with the application of field voltage and current flow on the winding. The resistance to ground increased from 12,000Ω to 1MΩ in about 3.5 hours and continued to climb. This gave us confidence that the right decision had been made.

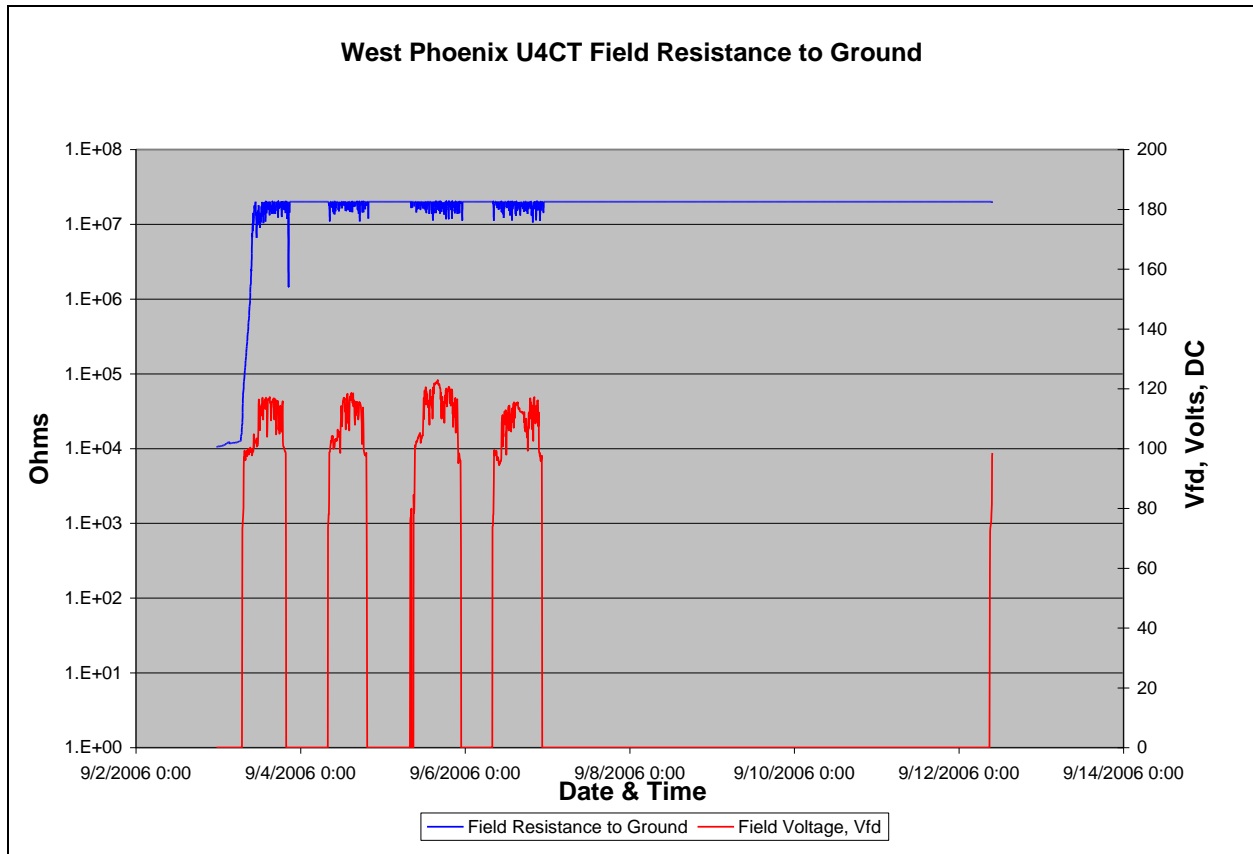

Figure 9
EFREM Data Following Ground Fault Event on September 2, 2006

Quite some time later, the diode wheel inspection hatch was opened to check on the mechanical integrity of the field connections to the EFREM transmitter. Some white powdery deposits were found around the diode wheel components that were not there at the time of EFREM installation. It is theorized that the water that was ingested into the cooling system left these deposits behind.

Future Work

EFREM has been upgraded to measure 80M Ω to ground insulation resistance. We plan to implement that upgrade as well as the capability to run a 4 to 20 milliampere current loop output of field resistance to ground directly into the plant's DCS. This will eliminate the problem of integrating the field resistance measurements into the plant's database. It makes the job of correlation with other data much easier. In addition, EFREM's manufacturer has plans to archive historical data right in the receiver unit so that it is not dependant on a continuous PC connection for data storage.

Not all brushless generators are configured with space to mount an EFREM transmitter on the end of the alternator/diode wheel shaft. Some designs have a permanent magnet generator (PMG) mounted outboard of the diode wheel. APS has two such base load machines that will be outfitted with a repackaged EFREM later this year as outages allow. **Figure 10** depicts a generator shaft mounted collar version of the EFREM transmitter that will be used at our plant.

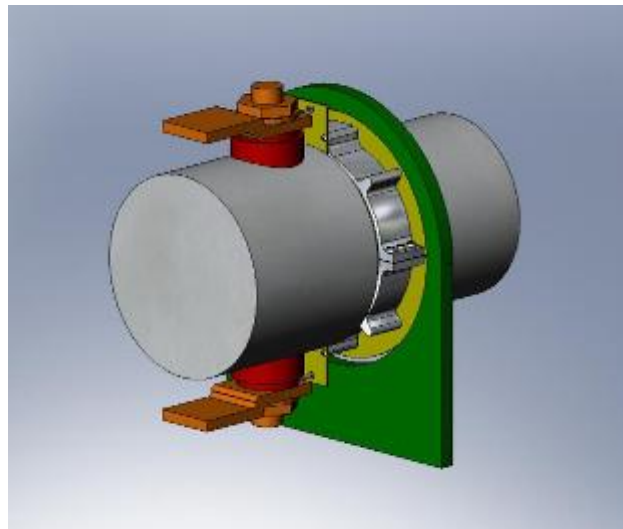

Figure 10
EFREM Collar Packaging for Mounting on Exciter Shaft

Conclusion

Based upon APS's experience at West Phoenix, we are convinced that our decision to use the EFREM was a wise choice. The ability to collect quantitative information on the fault resistance and location will prove invaluable in protecting generators and making informed decisions about continued operation of our units when ground faults are detected.

Contact us: Telemetry@Accumetrix.com
www.Accumetrix.com
Phone: 518-393-2200 Fax: 518-393-3622
409 Front Street, Schenectady NY 12305

R3